



RocketPort™ Serial Hub

Hardware Documentation

Product Overview

The RocketPort Serial Hub is based on the same technology as the popular RocketPort series. The RocketPort Serial Hub is a serial communications device that easily connects to a 10Base-T Ethernet hub or network interface card (NIC).

The RocketPort Serial Hub uses a 20 MHz processor specifically designed to process asynchronous serial communications, thereby maximizing performance and eliminating throughput bottlenecks.

The RocketPort Serial Hub uses Application Specific Integrated Circuits (ASICs) technology. ASIC technology increases reliability because it replaces many hardware components, which in turn reduces the number of parts that can fail.

RocketPort Serial Hub features include:

- Four or eight RJ45 asynchronous RS-232 serial ports.
- A power supply that supports input voltages between 100 and 240 and 50 or 60 Hz operation.
- “Hot-swapping,” which allows you to replace an existing and configured RocketPort Serial Hub with an identical unit, without downing the server or reconfiguring ports.
- Diagnostic LEDs.
- Backup server, which permits you to configure another server to take over the hub if the primary server fails (not all drivers support this feature).

What This Document Contains

Use this document to:

- [Connect](#) the RocketPort Serial Hub to the network.
- [Verify](#) that the RocketPort Serial Hub passes the hardware diagnostics during the power up phase.
- [Add](#) additional units to an existing RocketPort Serial Hub environment.
- [“Hot swap”](#) RocketPort Serial Hub units that have experienced a failure.
- [Build cables or loopback plugs](#), including:
 - An Ethernet crossover cable, if connecting the RocketPort Serial Hub directly to a NIC card (not included).
 - Null-modem cable for the peripheral devices that you are connecting to the RocketPort Serial Hub.
 - RS-232 loopback plug.
- [Troubleshoot](#) installation or configuration problems.
- Review the RocketPort Serial Hub [specifications](#) and [agency notices](#).
- [Contact](#) Control™ or download updated software or documentation.

See the RocketPort Serial Hub [Software Installation](#) documentation or the device driver [readme](#) file for software installation information. The software installation documentation may also provide information about supporting applications available with the driver for your operating system.

The latest driver releases are available at:

- <http://www.comtrol.com/coperate.htm>
- <ftp://ftp.comtrol.com/readme.htm>

Note: To use the red hyperlinks, you must be connected to the internet.

Installing the Mounting Brackets

1. On the bottom panel, remove two of the four screws that hold the box together.
2. Center the bracket over the holes and reinstall the screws.
3. Repeat steps 1 and 2 for the other bracket.

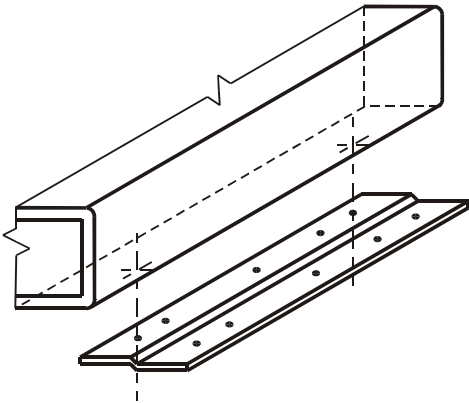

Connecting to the Network

Use the following procedure to connect the RocketPort Serial Hub to your server NIC card or Ethernet hub.

1. Record the media access control (MAC) address, model number, and serial number of the RocketPort Serial Hub.

Serial Number*	MAC*
	00 C0 4E 05 xx xx
	00 C0 4E 05 _ _ _ _

* ID tags are located on the bottom panel. You can write this information on the sticker shipped with the RocketPort Serial Hub.

2. Connect the cable from the Ethernet connection (10Base-T) on the RocketPort Serial Hub to your server NIC card or Ethernet hub.

Note: If connecting the RocketPort Serial Hub directly to a NIC, an **Ethernet crossover** cable is required. Control does not supply this. See the [Building an Ethernet Crossover Cable](#) discussion.

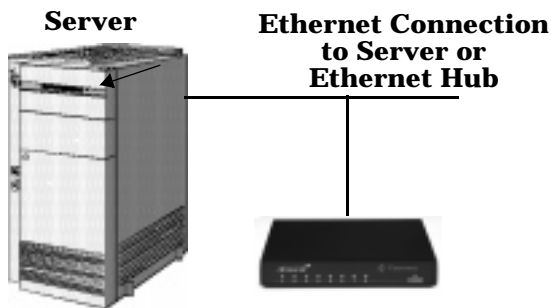

3. Connect the power adapter cable to the RocketPort Serial Hub port labeled POWER. Connect the power cord to the power adapter and plug the power cord into a power source.
4. Go to the [Running the Power On Diagnostics](#) discussion.

After you install and configure the driver, you can use the [Connecting Devices](#) discussion to connect your RS-232 serial devices.

Running the Power On Diagnostics

After you have connected the RocketPort Serial Hub to the NIC card or Ethernet hub, use the following information to determine if your RocketPort Serial Hub is working correctly.

1. Turn the power switch to the ON position.
2. Verify that the LEDs for Ports 1 through 4 or 8 (depending on the model) flash briefly after applying power, to confirm that the hardware is working properly.

Indicator	Port LED Descriptions
Flashes Briefly	All LEDs flash during the power-on test and then turn off. This indicates a successful self-check. Note: The Port 1 LED blinks while the RocketPort Serial Hub is waiting and goes out when the server initiates normal program activity.
1 LED Lit* Solid	Hardware failure. A RAM self-test failure or other mainboard error.
2 LEDs Lit*	Hardware failure. An Ethernet hardware initialization failure.
3 LEDs Lit*	A hardware self-test failure.
4 LEDs Lit*	A flash memory configuration error.

* The LEDs light up for a about a minute and then the hardware resets and the same cycle repeats.

- Verify that the lower green Ethernet LED remains on to determine that the 10Base-T connection and the polarity are correct.

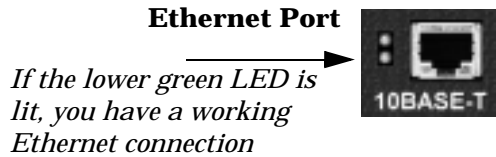

LED	Indicator	10Base-T LED Descriptions
Yellow Upper	Flashes Briefly	During the power on cycle (first few seconds after the power is turned on), this turns on briefly to display correct link polarity.
Yellow Upper	Flashing	The light flashes briefly during transmissions as a general indicator of activity.
Green Lower	On	RocketPort Serial Hub is correctly attached to the LAN and the Ethernet link is established.
Green Lower	Off	The Ethernet link is not established.

- Verify that the Port 1 LED is blinking. This indicates that the RocketPort Serial Hub is waiting for the server PC to download the driver.

Note: The Port 1 LED blinks while the RocketPort Serial Hub is waiting and goes out when the server initiates normal program activity.

- If the port LEDs do not display an error condition, then you are ready to install and configure the software. You can find software installation procedures in the *Software Installation* documentation or the device driver readme file.

- [Window 95/98](#)
- [Windows NT](#)
- [Windows 2000](#)

You can download the most recent driver and software installation document from the Comtrol web/ftp sites:

- <http://www.comtrol.com/coperate.htm>
- <ftp://ftp.comtrol.com/readme.htm>

Adding a Unit to an Existing Installation

Use this procedure to add another RocketPort Serial Hub to an existing configuration.

- Install the RocketPort Serial Hub using the [Connecting to the Network](#) discussion.
- Connect the RS-232 serial devices.
- Connect the RocketPort Serial Hub to your server NIC card or Ethernet hub.
- Power-up the new RocketPort Serial Hub and verify that it passes the power-on diagnostics.
- Configure VS-Link to support the new RocketPort Serial Hub. See the *Software Installation* documentation or the driver readme file.

- Configure the serial ports to support the RS-232 devices.
- Shut down and restart the server.

“Hot-Swapping” Hardware

Follow this procedure, to “hot-swap” a RocketPort Serial Hub with another RocketPort Serial Hub in an existing configuration.

- Power-down the RocketPort Serial Hub to be removed from service.
- Install a new or spare RocketPort Serial Hub.
- Connect the new RocketPort Serial Hub to the Ethernet hub or server NIC card.
- Power-up the new RocketPort Serial Hub and verify that it passes the power-on self-test.
- Change the driver to reflect the MAC address of the new RocketPort Serial Hub.
- Transfer *all* cabling from the old RocketPort Serial Hub to the new RocketPort Serial Hub. No port reconfiguration is needed.
- Do not* shut down and restart the server.

Troubleshooting

If you are having trouble with a RocketPort Serial Hub try the following.

Note: Most customer problems reported to Comtrol Technical Support are eventually traced to cabling or network problems.

- Verify that you are using the correct device driver. Device drivers for the *RocketPort Serial Hub* and the *RocketPort Serial Hub Si* are different.

Note: If you want to run both devices, you must install and configure both drivers.

- Verify that the unit is powered on and that the Power LED is lit.
- Turn the unit’s power switch off and on, while watching the LED diagnostics. For LED information, see the [Running the Power On Diagnostics](#) discussion.

Note: If the Port 1 is flashing, this indicates that the driver has not downloaded to the unit.

- Verify that the port polarity is correct. See the [Connecting to the Network](#) discussion.
- Verify that you are using the correct types of cables in the correct places and that all cables are connected securely.
- Verify that the Ethernet hub and any other network devices between the server and RocketPort Serial Hub are powered up and operating.
- To isolate the unit from the network, use a “crossover” Ethernet cable to connect the unit directly to the NIC card in the server.

8. If you are operating in a multiple-server environment, make sure that you are controlling the RocketPort Serial Hub from its primary server, that there is only one primary server assigned to this RocketPort Serial Hub, and that no backup server has pre-empted the primary server.
9. Backup-to-primary switching is not automatic. Once a backup server takes over control of a RocketPort Serial Hub, you must restore the primary server to operation, then cycle the power on the RocketPort Serial Hub in order to force the RocketPort Serial Hub to reattach itself to the primary server.
10. See the [Software Installation](#) documentation for information on operating system specific troubleshooting procedures.
11. If you have a spare RocketPort Serial Hub, try “hot-swapping” RocketPort Serial Hub units. See the [“Hot-Swapping” Hardware](#) discussion.

Note: *If this corrects the problem, the RocketPort Serial Hub that you have removed from service may be defective or in need of repair.*
12. Reboot the server.
13. Remove and reinstall the driver.
14. If you are unable to resolve the problem, [contact Technical Support](#).

Connecting Devices

Use the following discussion to connect RS-232 asynchronous devices to the RocketPort Serial Hub ports.

1. Connect your RS-232 devices to Ports 1 through 4 or 8 (depending on the model), for each RocketPort Serial Hub. RJ45 to DB25 cables are available from Control or you can build your own cables using the cabling discussions.

Note: *Use the hardware manufacturer’s installation documentation if you need help with connector pinouts or cabling for the peripheral device.*

2. Install or reconfigure the driver using the [Software Installation](#) documentation or the driver readme file.

Building an Ethernet Crossover Cable

If you are connecting from the 10Base-T connector on the RocketPort Serial Hub directly to the NIC card in the server, you need a crossover cable. Use the following information to build or purchase a cable.

Pin	Connects to Pin
1	3
2	6
3	1
6	2

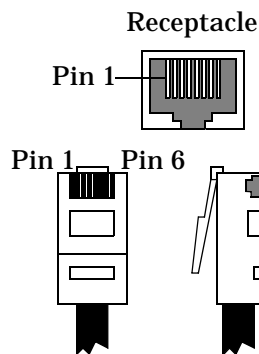

RS-232 Cabling

Use the following for pinout information for the RJ45 serial port connectors on the RocketPort Serial Hub.

RJ45 Pin	RS-232 Signals
1	RTS
2	DTR
3	GND
4	TxD
5	RxD
6	DCD
7	DSR
8	CTS

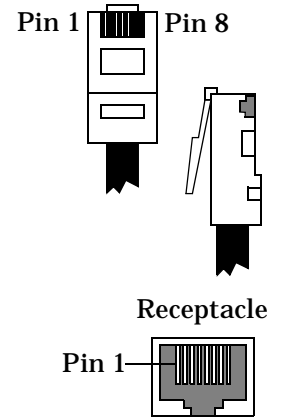

Building Additional Loopback Plugs

Loopback connectors are RJ45 female serial port plugs, with pins wired together as shown, that are used in conjunction with the diagnostic software to test serial ports. The RocketPort Serial Hub is shipped with a single loopback plug.

This information can help you build additional plugs or replace a missing loopback.

Use the following information to build loopback plugs.

- Pins 4 to 5
- Pins 1 to 8
- Pins 2 to 6 to 7

Note: *Do not insert the serial port loopback plug into the 10Base-T Ethernet connector.*

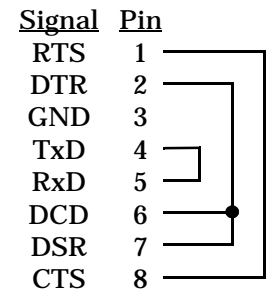

Building an RJ45 to DB25 Cable

Use the following figures if you need information about building a general-purpose DTE-to-DTE null modem cable or a DTE-to-DCE modem cable.

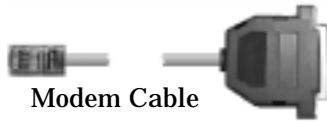

DTE-to-DCE Modem Cable*

Signal	Pin	Pin	Signal
RTS	1	4	RTS
DTR	2	20	DTR
GND	3	7	GND
TxD	4	2	TxD
RxD	5	3	RxD
DCD	6	8	DCD
DSR	7	6	DSR
CTS	8	5	CTS

* Can be ordered from Control.

General-Purpose DTE-to-DTE Null Modem Cable

Signal	Pin	Pin	Signal
TxD	4	2	TxD
RxD	5	3	RxD
RTS	1	4	RTS
CTS	8	5	CTS
DSR	7	20	DTR
DCD	6	8	DCD
DTR	2	6	DSR
SGND	3	7	SGND

Hardware Specifications

This table illustrates environmental conditions.

Environmental Conditions	Value
Air temperature: System on System off	0 to 40°C -20 to 85°C
Altitude	0 to 10,000 feet
Heat output: 4-Port 8-Port	17.1 BTU/Hr 20.5 BTU/Hr
Humidity (non-condensing): System on System off	8% to 80% 20% to 80%
Mean Time between Failures: 4-Port 8-Port	27.2 years 24.5 years

The following table lists electromagnetic compliance certifications.

Electromagnetic Compliances	Status
Emission: Canadian EMC requirements CISPR-22/EN55022 Class A FCC Part 15 Class A	Yes
Immunity: EN50082 (801-2 ESD, 801-3 RF, and 801-4 FT)	Yes
Safety: EN60950 UL Listed	Yes

The following table illustrates hardware specifications.

Topic	Hardware Specifications
Baud rate (maximum)	230.4 Kbps
Current consumption: 4-Port 8-Port	42 mA (at 120 VAC) 50 mA (at 120 VAC)
Dimensions 4-port 8-port	6" x 9" x 1.5" 6" x 9" x 2.4"
Driver Control: Data bits Parity Stop bits	7 or 8 Odd, Even, None 1 or 2
Ethernet host interface	10Base-T (10 Mbps)
Hubs per server	Dependent on OS. See the software documentation.
Line frequency	50 - 60 Hz
Line voltage	100 - 240 VAC
Number of ports	4 or 8
Power consumption: 4-Port 8-Port	5.0 W 6.0 W
Weight	1 lb 4 oz

Notices

Radio Frequency Interference (RFI) (FCC 15.105)

This equipment has been tested and found to comply with the limits for Class A digital devices pursuant to Part 15 of the FCC Rules.

This equipment generates, uses, and can radiate radio frequency energy, and if not installed and used in accordance with the instruction manual, may cause harmful interference to radio communications. However, there is no guarantee that interference will not occur in a particular installation. If this equipment does cause harmful interference to radio or television reception, which can be determined by turning the equipment off and on, the user is encouraged to try and correct the interference by one or more of the following measures:

- Reorient or relocate the receiving antenna.
- Increase the separation between the equipment and the receiver.
- Connect the equipment into an outlet on a circuit different from that to which the receiver is connected.
- Consult the dealer or an experienced radio/TV technician for help.

Labeling Requirements (FCC 15.19)

This equipment complies with part 15 of FCC rules. Operation is subject to the following two conditions:

- This device may not cause harmful interference, and
- This device must accept any interference received, including interference that may cause undesired operation.

Modifications (FCC 15.21)

Changes or modifications to this equipment not expressly approved by Comtrol Corporation may void the user's authority to operate this equipment.

Serial Cables (FCC 15.27)

This equipment is certified for Class A operation when used with unshielded cables.

Underwriters Laboratory

This equipment is Underwriters Laboratory "UL" listed.

Important Safety Information



Warning

To avoid contact with electrical current:

- Never install electrical wiring during an electrical storm.
- Never install the power plug in wet locations.
- Use a screwdriver and other tools with insulated handles.

Technical Support

If you need technical support, contact Comtrol using one of the following methods.

Corporate Headquarters:

- E-mail: support@comtrol.com
- FTP Site: <ftp://ftp.comtrol.com>
- Web Site: <http://www.comtrol.com>
- FAX: (763) 494-4199
- Phone: (763) 494-4100

Comtrol Europe:

- E-mail: support@comtrol.co.uk
- Web Site: <http://www.comtrol.co.uk>
- FAX: +44 (0) 1 869-323-211
- Phone: +44 (0) 1 869-323-220

Comtrol has a staff of technical support representatives to help you.

Trademark Notices

Comtrol, RocketPort, and VS-Link are trademarks of Comtrol Corporation.

Windows, MS-DOS, and Microsoft are registered trademarks of Microsoft Corporation.

Other product names mentioned herein may be trademarks and/or registered trademarks of their respective owners.

Second Edition, February 27, 2001

Copyright © 1998 - 2001. Comtrol Corporation.
All Rights Reserved.

Comtrol Corporation makes no representations or warranties with regard to the contents of this document or to the suitability of the Comtrol product for any particular purpose. Specifications subject to change without notice. Some software or features may not be available at the time of publication. Contact your reseller for current product information.

2000109 Revision C